

# WatchGuard AP430CR Hardware Guide

---

The WatchGuard AP430CR is a secure wireless access point designed for indoor/outdoor rugged deployment conditions and built with an industrial-rated IP67 enclosure.

The AP430CR features a Wi-Fi 6 802.11ax 2x2 2.4 GHz dual radio and 4x4 5 GHz dual concurrent radio that support up to 1148 Mbps data rate on the 2.4 GHz band and 2402 Mbps on the 5 GHz band.



The AP430CR also has a third 2x2 dual band radio for security scanning, and an integrated Bluetooth (BLE) radio.

Power is provided by a PoE+ (Power over Ethernet) power source.

# Access Point Management

You can manage WatchGuard Wi-Fi 6 access points with WatchGuard Cloud. WatchGuard Cloud delivers a simplified platform for Wi-Fi management to easily deploy, configure, and report on your wireless networks.

For quick start instructions on how to set up your access point with WatchGuard Cloud, go to: [watchguard.com/start](https://watchguard.com/start)

## About Your Hardware

### Hardware Specifications

Hardware	Description
Processor	Qualcomm Hawkeye IPQ8071A-1 Quad-core A53s @1.0GHz, Enterprise chip with I-Temp support
Memory	<ul style="list-style-type: none"><li>Flash: NOR Flash 8MB, NAND Flash 256MB</li><li>RAM: DDR4 512MB x 2</li></ul>
Radio Model	<ul style="list-style-type: none"><li>2.4 GHz Qualcomm Iron QCN5124-1 2x2 i-temp radio</li><li>5 GHz Qualcomm Iron QCN5154-1 4x4 i-temp radio</li><li>Scan radio: Qualcomm QCA9892 i-temp dual band 11ac 2x2 radio</li><li>Bluetooth: Qualcomm CSR8811A12 Bluetooth 4.0</li></ul>
Radio Type and Frequency Band	<ul style="list-style-type: none"><li>Radio 1: 2.4 GHz 2x2 802.11b/g/n/ax</li><li>Radio 2: 5 GHz 4x4 802.11a/n/ac/ax</li><li>Radio 3 (Scan): Dual band 802.11ac 2x2 radio</li></ul>
Antennas	<ul style="list-style-type: none"><li>Wi-Fi: 4 x 4/5dBi 2.4/5 GHz dual band N-type omnidirectional antennas</li><li>Scan Radio: 2 x 4/5dBi 2.4/5 GHz dual band N-type omnidirectional antennas</li><li>BLE: 1 x 4dBi 2.4 GHz external antenna</li></ul> <p>WatchGuard dual band omnidirectional dipole antennas (WG9004) are sold separately in packs of two antennas.</p> <p><b>Note: The device must have antennas connected for full range and functionality.</b></p>
Wireless Security	WPA3 PSK, WPA2 PSK, WPA3/WPA2 PSK, WPA3 Enterprise, WPA2 Enterprise, OWA
Ethernet Interfaces	<ul style="list-style-type: none"><li>1 x 5 GbE Ethernet port (Aquantia AQR114C)</li><li>1 x GbE Ethernet port (QCA AR8033). This LAN 2 port is discontinued in hardware revision M and higher.</li></ul>
Power Interface	PoE 54V DC 802.3at
Power Consumption	25.44W

Hardware	Description
MTBF (Mean Time Between Failures)	275,523 hours
Dimensions	267.1 mm x 217.65 mm x 53.7 mm (10.5" x 8.6" x 2.1")
Weight	1.759 kg (3.87 lbs)

## Environmental Requirements

To safely install your WatchGuard access point, we recommend that you:

- Install the device per local regulations
- Make sure the device has adequate clearance for air flow and cooling

Other environmental requirements:

Operating Temperature	-30°C to 60°C (-22°F to 140°F)
Operating Humidity	5% to 95% non-condensing
Non-operating Temperature	-40°C to 85°C (-40°F to 185°F)
Non-operating Humidity	5% to 95%, non-condensing

# Hardware Description



## Bottom Panel Connections

### *2.4/5GHz*

Antenna connectors for the dual band Wi-Fi radios.

### *2.4/5GHz Scan*

Antenna connector for the dual band security scanning radio.

### *LAN 1 (POE+)*

The LAN 1 port is a 5 GbE port that connects the access point to a wired LAN connection through a switch or hub. This port also provides PoE+ (802.3at) power for the access point.

### *LAN 2*

The LAN 2 port is a 1 GbE LAN port that you can use as a wired extension for an SSID network.

The LAN 2 port is discontinued in hardware revision M and higher.

### *Reset Button*

The reset button is located above the LAN 2 port. You must remove the weatherproof connector to access the LAN 2 port and the reset button.

The reset button and the LAN 2 port are discontinued in hardware revision M and higher. You can reset the access point from the command line interface (CLI). For more information, go to [Access Point Command Line Interface](#).

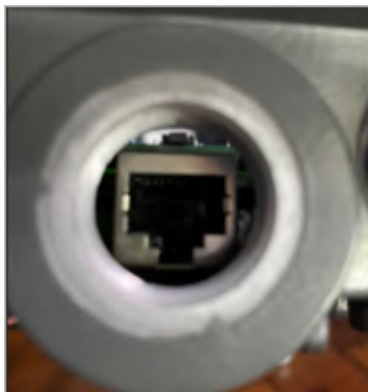

To reset the access point to factory-default settings:

- Remove the weatherproof connector from the LAN 2 port.
- Use a paper clip or other small object to press the reset button above the LAN 2 port.
- Press and hold the reset button for up to 10 seconds. When you release the reset button, all LEDs will go off to indicate that the access point has rebooted.

You can also reset the device from the access point command line interface (CLI). For more information, go to [Access Point Command Line Interface](#).

## Top Panel Connections



### *5GHz/BLE*

Antenna connector for the 5 GHz Wi-Fi and Bluetooth (BLE) radio.

### *2.4/5GHz Scan*

Antenna connector for the dual band security scanning radio.

### *5GHz*

Antenna connector for the 5 GHz Wi-Fi radio.

# Side Panel Connections

## LED Indicators



## LED Indicators

Wi-Fi in WatchGuard Cloud access points have LED indicators that can show different status conditions while booting, activation validation, feature key download, WatchGuard Cloud device registration, and the connection to WatchGuard Cloud.

The access point briefly passes through each stage until the device is connected to WatchGuard Cloud and shows a solid blue LED indicator. If the access point remains in the same state for a long period of time without a solid blue LED indicator status, there might be a network issue, activation or feature key issue, or a problem with your WatchGuard Cloud account.

Check the following table for the status of the LED indicators and how to troubleshoot the issue.

LED Color	Status	Troubleshooting
Solid Red or Orange	Device is booting	<p>If the access point remains in this state, the access point processes might not have started, or there might be an issue with the access point firmware.</p> <ul style="list-style-type: none"><li>■ Disconnect and reconnect power to reboot the access point to see whether the device connects.</li><li>■ Try to log in to the access point Web UI or command line interface (CLI) to check the device status, current firmware version, and run diagnostic tests. For more information, go to <a href="#">Access Point Web UI</a> or <a href="#">Access Point Command Line Interface</a>.</li></ul>
Flashing Red or Orange (Fast: 100 milliseconds)	Validate access point activation and download feature key	<p>If the access point remains in this state:</p> <ul style="list-style-type: none"><li>■ Make sure you have activated your access point with a valid device serial number and license key in your WatchGuard account. The license key must be for a WatchGuard Standard or USP Wi-Fi license for Wi-Fi in WatchGuard Cloud.</li><li>■ Make sure the access point is connected to the network and has received an IP address from DHCP.</li><li>■ Make sure the access point can connect to <code>*.watchguard.io</code> for product activation and feature key updates.</li></ul>

LED Color	Status	Troubleshooting
		<ul style="list-style-type: none"> <li>■ If you set up an access point behind a firewall that performs inspection on HTTPS traffic, you must add <i>*.watchguard.io</i> to the content inspection exception / bypass list to enable the access point to receive a feature key from WatchGuard servers. On the WatchGuard Firebox, this is enabled by default for cloud-managed Fireboxes in WatchGuard Cloud.</li> <li>■ Use the access point Web UI or command line interface (CLI) to check the feature key status, download a feature key, and run diagnostic tests. For more information, go to <a href="#">Access Point Web UI</a> or <a href="#">Access Point Command Line Interface</a>.</li> </ul>
Flashing Red or Orange (Medium: 500 milliseconds)	WatchGuard Cloud device registration	<p>If the access point remains in this state:</p> <ul style="list-style-type: none"> <li>■ Make sure access point can connect to <i>*.watchguard.com</i> for WatchGuard Cloud device registration.</li> <li>■ For service providers, make sure you have allocated the access point from your inventory to a subscriber account. For more information, see <a href="#">Access Point Allocation</a>.</li> <li>■ Make sure you have added the access point to your WatchGuard Cloud subscriber account. For more information, see <a href="#">Add an Access Point to WatchGuard Cloud</a></li> </ul>
Flashing Red or Orange (Slow: 2 seconds)	Connection to WatchGuard Cloud servers	<p>If the access point remains in this state:</p> <ul style="list-style-type: none"> <li>■ Make sure the access point can connect to <i>*.watchguard.com</i> for WatchGuard Cloud management connections and is not blocked by a firewall or other network device.</li> <li>■ Make sure you do not have an expired MSSP license for the access point.</li> <li>■ Check the access point allocation status to see whether the device was deallocated from the subscriber account.</li> </ul>
Solid Blue	Successfully connected to WatchGuard Cloud	Device is online and connected to WatchGuard Cloud.
Flashing Blue	Flash LED action from WatchGuard Cloud	LED flashes blue for 60 seconds for identification.
Flashing Blue and Red	Access point failed system integrity check	If the device LEDs flash alternating blue and red every second, the device has failed a system integrity check and has rebooted in failsafe mode. You must contact WatchGuard Support to replace the device.



# Mount and Connect the Access Point

Your package includes these wall mount and pole mount accessories:

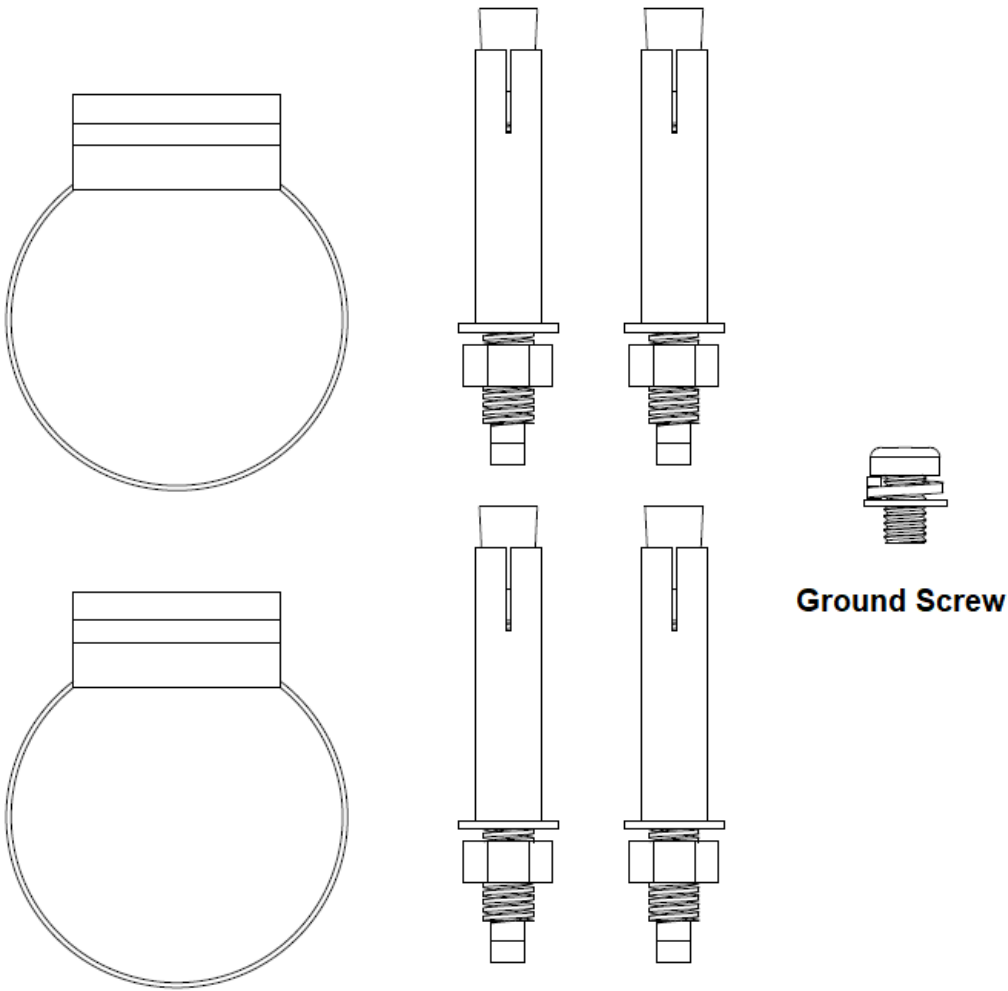

**Pole Mount Clamps**

**Wall Mount Screws**

**Ground Screw**

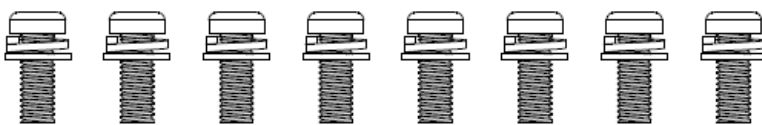

**Wall and Pole Mount Screws**

- 2 x Pole mount clamps
- 4 x Wall mount screws
- 8 x Wall and pole mount screws
- Ground screw

The MAC address and serial number of your access point are printed on a label on the back of the device. Make sure you record this information before you mount the device.

## Wall Mount Installation

Use the supplied wall-mounting accessories to install the access point on a wall.

1. Attach the access point to the wall mount bracket with the included screws.
2. Affix the access point and mounting bracket to the wall with the included screws.

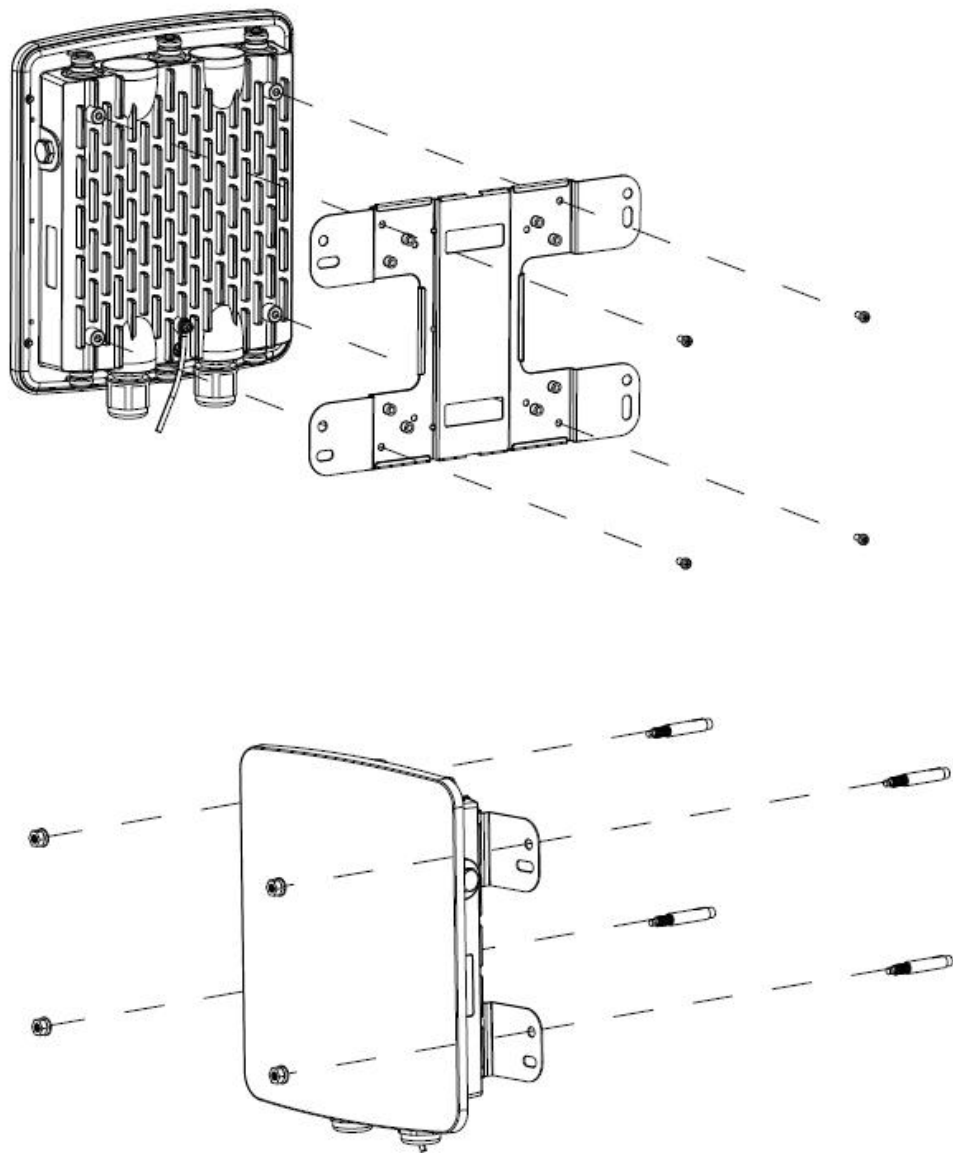

## Pole Mount Installation

Use the supplied pole-mounting accessories to install the access point on a pole.

1. Attach the wall mount bracket to the access point with the included screws.
2. Attach the pole mount bracket to the wall mount bracket and access point with the included screws.
3. Place the access point on the pole.
4. Insert the clamps in the slots on the pole mount bracket and wrap around the pole.

5. Fasten the screws and make sure the access point is firmly attached to the pole.

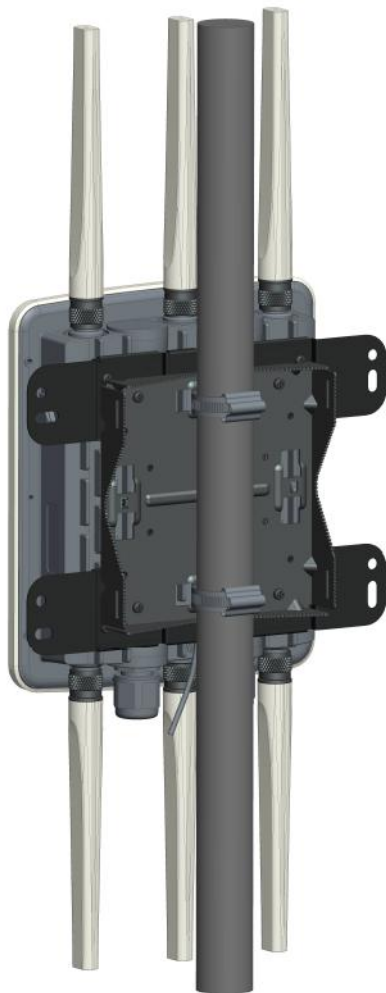
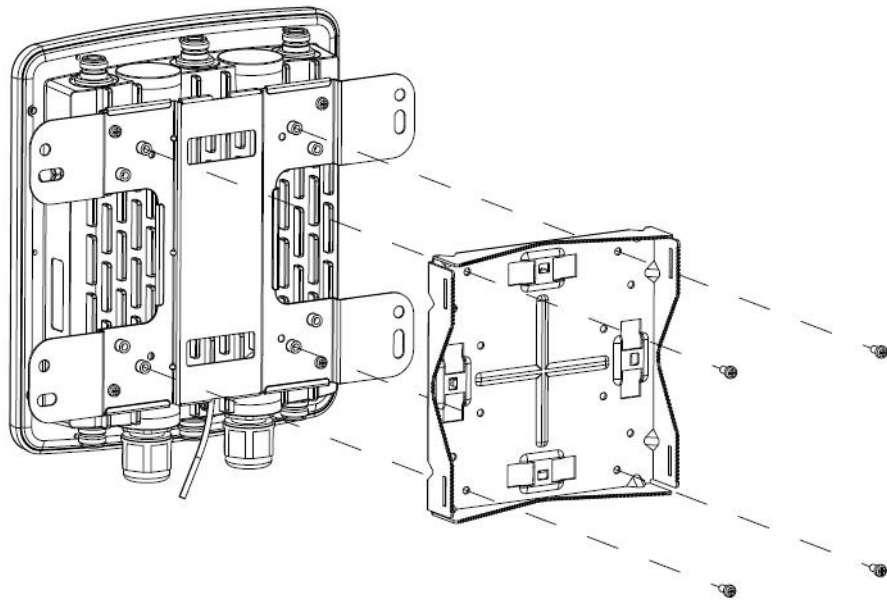

# Antenna Installation

WatchGuard dual band omnidirectional dipole antennas (WG9004) are sold separately in packs of two antennas.

The device must have antennas connected for full range and functionality.



- The access point requires a total of six antennas (two antennas for each radio band, and two antennas for the dual band scanning radio).
- On the top of the access point, there are two N-type connectors for the 2.4/5 GHz dual-band radios, and one connector for the scanning radio.
- On the bottom of the access point, there are two N-type connectors for the 5 GHz radios, and one connector for the scanning radio.

Insert the antennas into the connectors for each radio and turn clockwise to tighten.

You can use WatchGuard omnidirectional antennas or other third-party omnidirectional and directional antennas based on your deployment requirements. If you use other third-party antenna types, you are responsible for verifying compliance with regional-based regulations based on these peak gain values.

2.4 GHz			
Frequency (MHz)	2400	2450	2500
Peak Gain (dBi)	5.1	5.0	5.5
Efficiency (%)	78.3	76.4	83.2

5 GHz									
Frequency (MHz)	4900	5150	5250	5350	5450	5550	5650	5750	5850
Peak Gain (dBi)	6.1	6.5	6.4	6.7	7.2	6.6	6.6	7.0	6.9
Efficiency (%)	74.6	74.1	78.6	79.2	77.9	79.3	79.4	83.8	78.2

## Connect the Ground Wire

To make sure your access point is safely protected from electrical events, we recommend you ground the access point according to your local regulations.

Use the included screw to attach a ground wire to the ground connector on the back of the access point and to a nearby grounding point.



Ground Screw

## Connect the Access Point

Plug one end of the Ethernet cable from your network into the LAN 1 (PoE+) port on the bottom panel of the access point.

Make sure the other end of the Ethernet cable is connected to your network through a hub, switch, or injector with PoE+ (802.3at) power enabled.



Access Point connected to PoE+ injector



Access Point connected to switch with PoE+ power

# How to Assemble the Weatherproof Connector

Use these instructions to connect the Ethernet cable to the access point through the weatherproof connector.

**1**

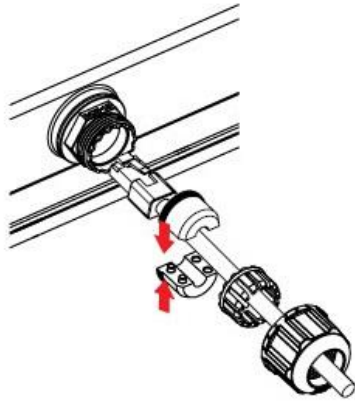

**2**

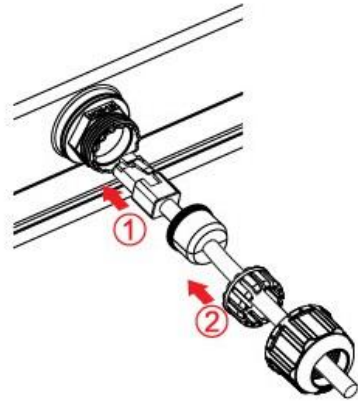

**3**

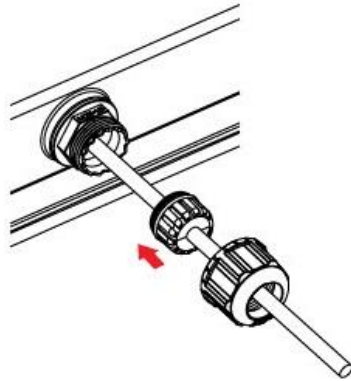

**4**

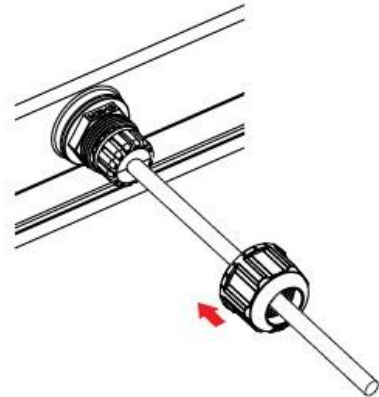

**5**

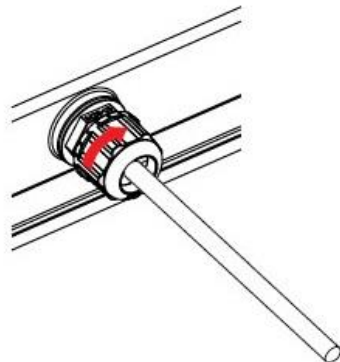



# How to Disassemble the Weatherproof Connector

Use these instructions to disconnect the Ethernet cable from the weatherproof connector.

**1**

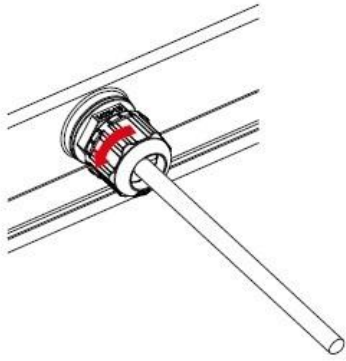

**2**

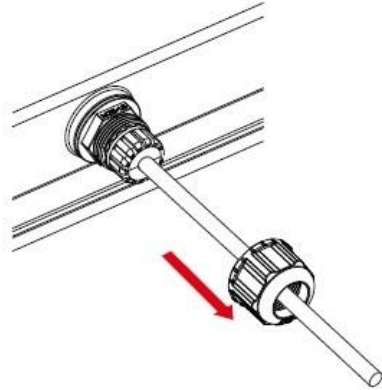

**3**

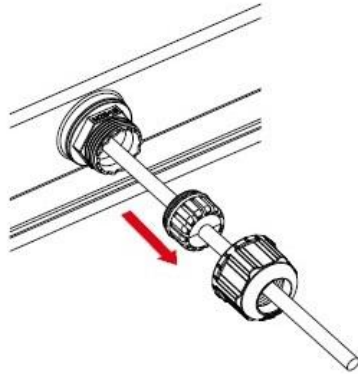

**4**

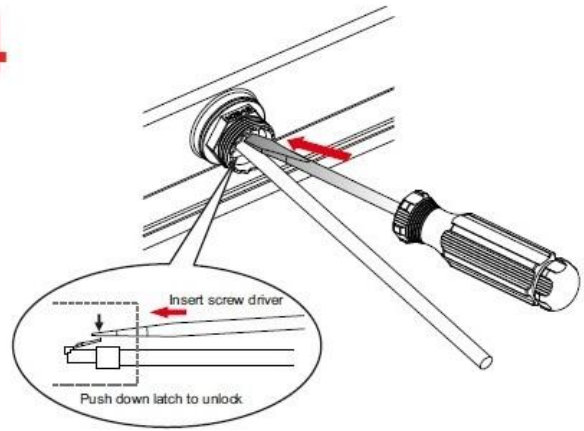

**5**

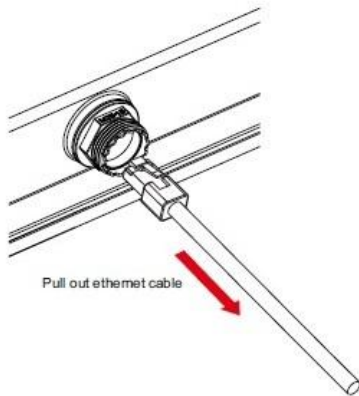

## Ethernet Power Injector (Optional)

You can power the access point with an optional Ethernet Power Injector. The PoE+ power injector enables you to power the access point through an existing Ethernet connection. With this device, you do not have to position your access point near a power outlet.



This device complies with IEEE 802.3at/af PoE specifications. Do not use any PoE adapters that are not IEEE 802.3at/af compliant as they may damage your device.

To connect an Ethernet Power Injector to the WatchGuard access point:

1. Plug the Ethernet Power Injector into an AC power source.
2. Connect an Ethernet cable from your network backbone (for example, a PoE-capable router, switch, or hub) to the **LAN** connector on the Ethernet Power Injector.
3. Connect an Ethernet cable from the **LAN1 PoE** Ethernet interface on the access point to the **PoE** connector on the Ethernet Power Injector.

The table provides the specifications for the power adapter.

Ethernet Power Injector Specs	
WatchGuard Part Number	802.3at PoE+ Injector with AC cord (US/FCC) (WG8599) 802.3at PoE+ Injector with AC cord (CE) (WG8600) 802.3at PoE+ Injector with AC cord (UK) (WG8601) 802.3at PoE+ Injector with AC cord (AUS) (WG8602)
Specification	IEEE 802.3at/af
AC Input Voltage Rating	100-240VAC
Input Current	0.8A max for 100VAC

## Ethernet Power Injector Specs

Output Power	30W maximum
Ethernet Interfaces	LAN: RJ-45 for 10/100/1000/2500 Mbps data POE: RJ-45 for 10/100/1000/2500 Mbps data and power Voltage: Pin4, 5:54V, Pin7, 8:Return
Indicator	Power: Green
Temperature	Operating: 0 - 40°C (32 - 104°F) Storage: -30 - 80°C (-22 - 176°F)
Humidity	5% - 90% (Operating and storage)
Dimensions	L = 99 mm (3.9") W = 68.5 mm (2.27") H = 33 mm (1.3")
Weight	149.6 g (0.33 lbs)

# Notices

All WatchGuard products are designed and tested to meet strict safety requirements. These requirements include product safety approvals and other global compliance standards. Please read these instructions carefully before operating the product, and refer to them as needed to ensure the continued safe operation of your product.

For patent information, please visit <http://www.watchguard.com/patents>

## Safety Warning

- Do not place objects on the power cord.
- Do not obstruct the ventilation openings. These openings prevent overheating of the machine.
- Never push objects of any kind into slots or openings on this equipment. Making a contact with a voltage point or shorting out a part may result in fire or electrical shock.
- When removing or installing an device, follow the general installation safety instructions.

## Power Source Requirements

This product is intended to be supplied by a Listed Power Adapter or DC power source marked "L.P.S." (or Limited Power Source or PS2) rated 12V DC, 2A minimum, maximum ambient temperature (Tma)=40°C, or supplied by a Listed PoE Adapter marked "L.P.S." (or Limited Power Source or PS2) rated 54V DC, 0.6A minimum, maximum ambient temperature (Tma)=40°C. For more information regarding approved power sources, please contact WatchGuard Technologies.

Connect the PoE interface only to PoE networks, without routing to the outside plant.

If protective earthing is used as a safeguard, the instructions shall require connection of the equipment protective earthing conductor to the installation protective earthing conductor (for example, by means of a power cord connected to a socket-outlet with earthing connection). To meet safety and electromagnetic interference (EMI) requirements, you must make sure the power source is connected to earth ground before you connect power to the access point.

## Disclaimer

WatchGuard shall not be held liable if the end user alters, modify, or repairs any WatchGuard hardware appliance.

## Avis

Tous les produits WatchGuard sont conçus et testés pour répondre à des exigences de sécurité strictes. Ces exigences comprennent les approbations de sécurité des produits et d'autres normes de conformité mondiales. Veuillez lire attentivement ces instructions avant d'utiliser le produit, et consultez-les si nécessaire pour assurer le fonctionnement continu et sûr de votre produit.

## Alerte de sécurité

- Ne placez pas d'objets sur le cordon d'alimentation.
- Ne pas obstruer les ouvertures de ventilation. Ces ouvertures évitent la surchauffe de la machine.
- N'introduisez jamais d'objets d'aucune sorte dans les fentes ou les ouvertures de cet équipement. Établir un contact avec un point de tension ou court-circuiter une pièce peut entraîner un incendie ou un choc électrique.
- Lors du retrait ou de l'installation d'un appareil, respectez les consignes générales de sécurité d'installation.

## Exigences relatives à la source d'alimentation

Ce produit est destiné à être alimenté par un adaptateur secteur répertorié ou une source d'alimentation CC portant la mention "L.P.S." (ou source d'alimentation limitée ou PS2) de 12 V CC, 2 A minimum, température ambiante maximale (Tma) = 40 °C, ou fourni par un adaptateur PoE répertorié marqué "L.P.S." (ou source d'alimentation limitée ou PS2) nominale 54 V CC, 0,6 A minimum, température ambiante maximale (Tma) = 40

°C. Pour plus d'informations sur les sources d'alimentation approuvées, veuillez contacter WatchGuard Technologies.

Connectez l'interface PoE uniquement aux réseaux PoE, sans routage vers l'installation extérieure.

Si la mise à la terre de protection est utilisée comme protection, les instructions doivent exiger la connexion du conducteur de mise à la terre de protection de l'équipement au conducteur de mise à la terre de protection de l'installation (par exemple, au moyen d'un cordon d'alimentation connecté à une prise de courant avec mise à la terre). Pour répondre aux exigences de sécurité et d'interférence électromagnétique (EMI), vous devez vous assurer que la source d'alimentation est connectée à la terre avant de connecter l'alimentation au point d'accès.

## Clause de non-responsabilité

WatchGuard décline toute responsabilité si l'utilisateur final altère, modifie ou répare une appliance matérielle WatchGuard.

## HINWEISE ZUR SICHERHEIT

Alle WatchGuard Produkte werden entwickelt und getestet, um strenge Sicherheitsanforderungen zu erfüllen. Diese Anforderungen umfassen Produktsicherheitszulassungen und andere globale Compliance-Standards. Bitte lesen Sie die folgenden Anweisungen sorgfältig, bevor Sie das Produkt, und bezeichnen sie als notwendig, um den sicheren Betrieb des Geräts zu gewährleisten.

### Sicherheitshinweis

- Legen Sie keine Gegenstände auf das Netzkabel.
- Verdecken Sie nicht die Lüftungsöffnungen. Diese Öffnungen verhindern eine Überhitzung der Maschine.
- Stecken Sie niemals Gegenstände jeglicher Art in die Schlitze oder Öffnungen des Geräts stecken. Der Kontakt mit einem spannungsführenden Punkt oder das Kurzschließen eines Bauteils kann zu einem Brand oder elektrischen Schlag führen.
- Beim Entfernen oder Installieren eines Gerätes, nach den allgemeinen Installation Sicherheitshinweise.

### Anforderungen an die Stromquelle

Dieses Produkt ist für die Versorgung mit einem gelisteten Netzteil oder einer DC-Stromquelle mit der Kennzeichnung „L.P.S.“ vorgesehen. (oder Limited Power Source oder PS2) mit einer Nennleistung von mindestens 12 V DC, 2 A, maximale Umgebungstemperatur (T<sub>ma</sub>) = 40 °C oder über einen gelisteten PoE-Adapter mit der Kennzeichnung „L.P.S.“ (oder Limited Power Source oder PS2) Nennwert 54 V DC, 0,6 A Minimum, maximale Umgebungstemperatur (T<sub>ma</sub>) = 40 °C. Wenden Sie sich für weitere Informationen zu zugelassenen Stromquellen bitte an WatchGuard Technologies.

Verbinden Sie die PoE-Schnittstelle nur mit PoE-Netzwerken, ohne Routing zur Außenanlage.

Wenn eine Schutzerdung als Schutz verwendet wird, müssen die Anweisungen den Anschluss des Schutzerdungsleiters des Geräts an den Schutzerdungsleiter der Installation fordern (z. B. über ein Netzkabel, das an eine Steckdose mit Erdungsanschluss angeschlossen ist). Um die Sicherheits- und elektromagnetischen Interferenzanforderungen (EMI) zu erfüllen, müssen Sie sicherstellen, dass die Stromquelle geerdet ist, bevor Sie den Access Point an die Stromversorgung anschließen.

### Haftungsausschluss

WatchGuard haftet nicht, wenn der Endbenutzer eine Hardware-Appliance von WatchGuard ändert, modifiziert oder repariert.

## Avisos

Todos los productos WatchGuard están diseñados y probados para cumplir estrictos requisitos de seguridad. Estos requisitos incluyen aprobaciones de seguridad de productos y otros estándares de cumplimiento mundial. Lea atentamente estas instrucciones antes de utilizar el producto y consúltelas siempre que sea necesario para garantizar un funcionamiento seguro y continuo del mismo.

### Advertencia de Seguridad

- No coloque objetos sobre el cable de alimentación.

- No obstruya las aberturas de ventilación. Estas aberturas evitan el sobrecalentamiento de la máquina.
- Nunca introduzca objetos de ningún tipo en las ranuras o aberturas del equipo. El contacto con puntos de voltaje o el cortocircuito de una pieza podría provocar un incendio o una descarga eléctrica.
- Al extraer o instalar un dispositivo, siga las instrucciones generales de instalación de seguridad.

## Requisitos de la Fuente de Alimentación

Este producto está diseñado para ser alimentado por un Adaptador de Corriente Listado o una fuente de alimentación de CC marcada como "L.P.S." (o Fuente de Alimentación Limitada o PS2) nominal de 12 V CC, 2 A mínimo, temperatura ambiente máxima (Tma) = 40 °C, o alimentado por un Adaptador PoE Listado marcado como "L.P.S." (o Fuente de Alimentación Limitada o PS2) nominal de 54 V CC, 0,6 A mínimo, temperatura ambiente máxima (Tma) = 40 °C. Para obtener más información sobre las fuentes de alimentación aprobadas, comuníquese con WatchGuard Technologies.

Conecte la interfaz PoE solo a redes PoE, sin enrutamiento a la planta exterior.

Si se utiliza la puesta a tierra de protección como medida de seguridad, las instrucciones deben exigir la conexión del conductor de puesta a tierra de protección del equipo al conductor de puesta a tierra de protección de la instalación (por ejemplo, mediante un cable de alimentación conectado a un tomacorriente con conexión a tierra). Para cumplir con los requisitos de seguridad e interferencia electromagnética (EMI), debe asegurarse de que la fuente de alimentación esté conectada a tierra antes de conectar la alimentación al punto de acceso.

## Descargo de Responsabilidad

WatchGuard no será responsable si el usuario final altera, modifica o repara cualquier dispositivo de hardware de WatchGuard.

## FCC Certification (USA)

This device complies with part 15 of the FCC Rules. Operation is subject to the following two conditions: (1) This device may not cause harmful interference, and (2) this device must accept any interference received, including interference that may cause undesired operation.

This equipment has been tested and found to comply with the limits for a Class B digital device, pursuant to part 15 of the FCC Rules. These limits are designed to provide reasonable protection against harmful interference in a residential installation.

This equipment generates, uses and can radiate radio frequency energy and, if not installed and used in accordance with the instructions, may cause harmful interference to radio communications. However, there is no guarantee that interference will not occur in a particular installation. If this equipment does cause harmful interference to radio or television reception, which can be determined by turning the equipment off and on, the user is encouraged to try to correct the interference by one or more of the following measures:

- Reorient or relocate the receiving antenna.
- Increase the separation between the equipment and receiver.
- Connect the equipment into an outlet on a circuit different from that to which the receiver is connected.
- Consult the dealer or an experienced radio/TV technician for help.

FCC Caution: Any changes or modifications not expressly approved by the party responsible for compliance could void the user's authority to operate this equipment.

This transmitter must not be co-located or operating in conjunction with any other antenna or transmitter.

This device meets all the other requirements specified in Part 15E, Section 15.407 of the FCC Rules.

### Radiation Exposure Statement:

This equipment complies with FCC radiation exposure limits set forth for an uncontrolled environment. This equipment should be installed and operated with minimum distance 40cm between the radiator & your body.

## ISED Certification (Canada)

This device complies with ISED's licence-exempt RSSs. Operation is subject to the following two conditions: (1) This device may not cause harmful interference, and (2) this device must accept any interference received, including interference that may cause undesired operation.

Le présent appareil est conforme aux CNR d'ISED applicables aux appareils radio exempts de licence. L'exploitation est autorisée aux deux conditions suivantes: (1) le dispositif ne doit pas produire de brouillage préjudiciable, et (2) ce dispositif doit accepter tout brouillage reçu, y compris un brouillage susceptible de provoquer un fonctionnement indésirable.

### Caution

For devices with detachable antenna(s), the maximum antenna gain permitted for devices in the bands 5250-5350 MHz and 5470-5725 MHz must be such that the equipment still complies with the e.i.r.p. limit.

For devices with detachable antenna(s), the maximum antenna gain permitted for devices in the band 5725-5850 MHz must be such that the equipment still complies with the e.i.r.p. limits as appropriate.

For systems that are capable of operating outdoors or with antennas mounted outdoors (where applicable antenna type(s), antenna models(s), and worst-case tilt angle(s)) are necessary to remain compliant with the e.i.r.p, therefore, the elevation mask requirement set forth in section 6.2.2.3 should be clearly indicated.

### Avertissement

Pour les appareils avec antenne(s) amovible(s), le gain d'antenne maximal autorisé pour les appareils dans les bandes 5250-5350 MHz et 5470-5725 MHz doit être tel que l'équipement soit toujours conforme à la e.i.r.p. limite.

Pour les appareils avec antenne(s) amovible(s), le gain d'antenne maximal autorisé pour les appareils dans la bande 5725-5850 MHz doit être tel que l'équipement soit toujours conforme à la p.i.r.e. limites le cas échéant.

Lorsqu'il y a lieu, les types d'antennes (s'il y en a plusieurs), les numéros de modèle de l'antenne et les pires angles d'inclinaison nécessaires pour rester conforme à l'exigence de la p.i.r.e. applicable au masque d'élévation, énoncée à la section 6.2.2.3, doivent être clairement indiqués

### Radiation Exposure Statement

This equipment complies with ISED radiation exposure limits set forth for an uncontrolled environment. This equipment should be installed and operated with minimum distance 42cm between the radiator & your body.

### Déclaration d'exposition aux radiations

Cet équipement est conforme aux limites d'exposition aux rayonnements ISED établies pour un environnement non contrôlé. Cet équipement doit être installé et utilisé avec un minimum de 42cm de distance entre la source de rayonnement et votre corps.

## European Union (CE)

This device complies with the essential requirements of the RED Directive 2014/53/EU. The following test methods have been applied in order to prove presumption of conformity with the essential requirements of the RED Directive 2014/53/EU:

**EN 62368-1:2014+A11:2017**

Safety of Information Technology Equipment (ITE)

**EN 55024:2010+A1:2015**

Immunity for Information Technology Equipment (ITE)

**EN 55032:2015+A11:2020**

Electromagnetic compatibility of multimedia equipment - Emission requirements.

**EN 55035: 2017/A11:2020**

Electromagnetic compatibility of multimedia equipment — Immunity Requirements

**EN 61000-3-2:2014**

Limits for harmonic current emissions.

**EN 61000-3-3:2013**

Limitation of voltage changes, voltage fluctuations and flicker in public low-voltage supply systems, for equipment with rated current  $\leq 16$  A per phase and not subject to conditional connection.

**EN 62311:2008**

Assessment of electronic and electrical equipment related to human exposure restrictions for electromagnetic fields (0 Hz - 300 GHz).

**EN 301 489-1 v2.2.3 (2019-11)**

Electromagnetic compatibility and Radio spectrum Matters (ERM); Electro Magnetic Compatibility (EMC) standard for radio equipment and services; Part 1: Common technical requirements

**EN 301 489-17 v3.1.1 (2017-02)**

Electromagnetic compatibility and Radio spectrum Matters (ERM); ElectroMagnetic Compatibility (EMC) standard for radio equipment; Part 17: Specific conditions for Broadband Data Transmission Systems

**EN 300 328 v2.2.2 (2019-07)**

Electromagnetic compatibility and Radio spectrum Matters (ERM); Wideband transmission systems; Data transmission equipment operating in the 2.4 GHz ISM band and using wide band modulation techniques; Harmonized EN covering the essential requirements of article 3.2 of the RED Directive

**EN 301 893 v2.1.1 (2017-05)**

Broadband Radio Access Networks (BRAN); 5 GHz high performance RLAN; Harmonized EN covering the essential requirements of article 3.2 of the RED Directive

**EN 50385: 2017**

This product standard is related to human exposure to radio frequency electromagnetic fields transmitted by base station equipment in the frequency range 110 MHz to 100 GHz.

This device has software that cannot affect compliance with the Radio Equipment Directive (RED) 2014/53/EU, even if the software is changed or replaced.

This device is a 5 GHz wideband transmission system (transceiver), intended for use in all EU member states and EFTA countries, except in France and Italy where restrictive use applies.

This device is restricted to indoor use when operating in the 5150 to 5350 MHz frequency range in the indicated countries.

Dieses Gerät verfügt über Software, die die Einhaltung der Richtlinie über Funkanlagen (RED) 2014/53/EU nicht beeinträchtigen kann, selbst wenn die Software geändert oder ersetzt wird.

Dieses Gerät ist ein 5-GHz-Breitband-Übertragungssystem (Transceiver), das für die Verwendung in allen EU-Mitgliedstaaten und EFTA-Ländern bestimmt ist, außer in Frankreich und Italien, wo eine eingeschränkte Verwendung gilt.



Dieses Gerät ist auf die Verwendung in Innenräumen beschränkt, wenn es in den angegebenen Ländern im Frequenzbereich von 5150 bis 5350 MHz betrieben wird.

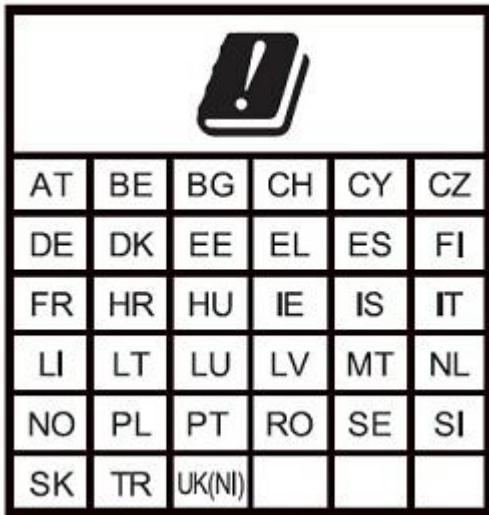

Frequency Range	Maximum Output Power (EIRP)
2412 - 2472 MHz	19.99 dBm
5500 - 5700 MHz	29.89 dBm

In Italy the end-user should apply for a license at the national spectrum authorities in order to obtain authorization to use the device for setting up outdoor radio links and/or for supplying public access to telecommunications and/or network services.

In Italien sollte der Endbenutzer eine Lizenz bei den nationalen Frequenzbehörden beantragen, um die Genehmigung zu erhalten, das Gerät zum Aufbau von Funkverbindungen im Freien und/oder zur Bereitstellung des öffentlichen Zugangs zu Telekommunikations- und/oder Netzwerkdiensten zu verwenden.

Restrictions: France (i) les dispositifs fonctionnant dans la bande 5150-5250 MHz sont réservés uniquement pour une utilisation à l'intérieur afin de réduire les risques de brouillage préjudiciable aux systèmes de satellites mobiles utilisant les mêmes canaux; (ii) De plus, les utilisateurs devraient aussi être avisés que les utilisateurs de radars de haute puissance sont désignés utilisateurs principaux (c.-à-d., qu'ils ont la priorité) pour les bandes 5 250-5 350 MHz et 5 650-5 850 MHz et que ces radars pourraient causer du brouillage et/ou des dommages aux dispositifs LAN-EL.

Einschränkungen: Frankreich –(i)-Geräte, die im Band 5150-5250 MHz ist nur für den Innenbereich, um das Risiko von Störungen des mobilen Satelliten-Systeme, die die gleichen Kanäle (ii) Darüber hinaus reduzieren vorbehalten, sollten Benutzer auch darauf hingewiesen werden, dass die Nutzer von Hochleistungs-Radare bezeichnet werden primäre Benutzer (dh d. sie haben Priorität) der Bänder 5 250-5 350 MHz und 5 650-5 850 MHz und dass diese Radargeräte können Störungen und / oder Schäden an LE-LAN-Geräten verursachen.

Български	Този продукт е в съответствие с Директива 2014/53/ЕС.
Česky	Tento produkt je v souladu se směrnici 2014/53/EU.
Dansk	Dette produkt er i overensstemmelse med direktiv 2014/53/EU.
Deutsch	Dieses Produkt entspricht der Richtlinie 2014/53/EU.
Eesti	See toode vastab direktiivile 2014/53/EL.
English	This product is in compliance with Directive 2014/53/EU.
Español	Este producto cumple con la Directiva 2014/53/UE.
Ελληνική	Το προϊόν αυτό συμμορφώνεται με την Οδηγία 2014/53/ΕΕ.

Français	Ce produit est conforme à la Directive 2014/53/UE.
Hrvatski	Ovaj proizvod je u skladu s Direktivom 2014/53/EU.
Italiano	Questo prodotto è conforme alla Direttiva 2014/53/EU.
Latviski	Šis produkts atbilst Direktīvai 2014/53/EU.
Lietuvių	Šis gaminys atitinka direktyvą 2014/53/ES.
Malti	Dan il-prodott huwa konformi mad-Direttiva 2014/53/UE.
Magyar	Ez za termék megfelel a 2014/53/EU irányelvnek.
Nederlands	Dit product is in overeenstemming met Richtlijn 2014/53/EU.
Norsk	Denne produktet er i samsvar med direktiv 2014/53/EU.
Polski	Ten produkt jest zgodny z dyrektywą 2014/53/UE.
Português	Este produto está em conformidade com a Diretiva 2014/53/UE.
Rumunski	Acest produs este în conformitate cu Directiva 2014/53/UE.
Slovensky	Tento produkt je v súlade so smernicou 2014/53/EÚ.
Slovensko	Ta izdelek je v skladu z Direktivo 2014/53/EU.
Suomi	Tämä tuote on direktiivin 2014/53/EU mukainen.
Svenska	Denna produkt överensstämmer med direktiv 2014/53/EU.

# Declaration of Conformity

WatchGuard Technologies, Inc.  
505 Fifth Ave. S., Suite 500  
Seattle, WA 98104-3892 USA

WatchGuard Technologies Inc. hereby declares that the product(s) listed below conform to the European Union directives and standards identified in this declaration.

**Product(s):**

802.11a/b/g/n/ac/ax Access Point, AP430CR

**EU Directives(s):**

Low Voltage (2014/35/EU)  
Electromagnetic Compatibility (2014/30/EU)  
Energy-related Products (2009/125/EC)  
RoHS (2011/65/EU and 2015/863/EU RoHS)  
WEEE Directive 2012/19/EU  
The Radio Equipment Directive (2014/53/EU)

**Common Standard(s):**

EN 62368-1:2014+A11:2017	Safety for ITE
EN 55024:2010	
EN 55024:2010+A1:2015	Immunity for ITE
EN 55032:2015+A11:2020	
EN 55035:2017/A11:2020	
EN 61000-3-2:2014	Harmonics
EN 61000-3-3:2013	Flicker

**Wireless Standard(s):**

EN 62311:2008	
EN 301 489-1 v2.2.3 (2019-11)	EMC and Radio Spectrum Matters
EN 301 489-17 v3.1.1 (2017-02)	EMC and Radio Spectrum Matters
EN 300 328 v2.2.2 (2019-07)	Radio Spectrum Matters
EN 301 893 v2.1.1 (2017-05)	Broadband Radio Access Networks
EN 50385:2017	

This device complies with Directive 2014/53/EU issued by the Commission of the European Community.

Manufacturer / Hersteller:	WatchGuard Technologies 505 5th Ave S. Suite 500, Seattle, WA 98104 USA
Radio Equipment / Funkanlage:	802.11a/b/g/n/ac/ax Access Point
Type Designation / Typenbezeichnung:	AP430CR
Specifications / Technische Daten:	802.11a/b/g/n/ac/ax (2.4GHz & 5GHz)
Intended Purpose / Verwendungszweck:	Cloud managed wireless outdoor access point
Equipment Class / Betriebsmittel der Klasse:	Class II
Operating temperature / Betriebstemperatur:	-30° C to 60° C

The above device complies with the essential requirements and other relevant provisions to Directive 2014/53/EU when used for its intended purpose. This equipment may be operated in the USA, Canada, & Europe Union.

Die oben genannten Gerät entspricht den grundlegenden Anforderungen und anderen relevanten Bestimmungen der Richtlinie 2014/53/EU, wenn für den vorgesehenen Zweck verwendet werden. Dieses Gerät ist für die Verwendung in den USA, Kanada, and Europäische Union.

Signature

*Laurence Huang*



Full Name: Laurence Huang  
Position: Manufacturing Program Manager  
Date and Place of Issue: 15 May 2021, Seattle, WA, USA

A full list of safety approvals, global compliance standards, and certifications can be found in the Hardware Guide for this device located on the WatchGuard website: <https://www.watchguard.com/wgd-help/documentation/hardware-guide>

## Brazil ANATEL Notice

Este equipamento não tem direito à proteção contra interferência prejudicial e não pode causar interferência em sistemas devidamente autorizados.

## CISPR 22 Statement

Este produto não é apropriado para uso em ambientes domésticos, pois poderá causar interferências eletromagnéticas que obrigam o usuário a tomar medidas necessárias para minimizar estas interferências.

This is a class A product. In a domestic environment, this product may cause radio interference in which case the user may be required to take adequate measures.

## Mexico NOM Notice

La operación de este equipo está sujeta a las siguientes dos condiciones:

(i) es posible que este equipo o dispositivo no cause interferencia perjudicial y

(ii) este equipo o dispositivo debe aceptar cualquier interferencia, incluyendo la que pueda causar su operación no deseada.

## Japan Statement

この装置には、電波法に基づく技術規則適合証明書 の認定を受けた特定の無線装置が含まれています。

W52/W53屋内使用限定ただし登録局に接続される場合は除

## Japan VCCI Class B Statement

この装置は、情報処理装置等電波障害自主規制協議会 (VCCI) の基準に基づくクラス B 情報技術装置です。この装置は、家庭環境で使用することを目的としていますが、この装置がラジオやテレビジョン受信機に近接して使用されると、受信障害を引き起こすことがあります。取扱説明書に従って正しい取り扱いをして下さい。

## Taiwan NCC Statement

取得審験證明之低功率射頻器材，非經核准，公司、商號或使用者均不得擅自變更頻率、加大功率或變更原設計之特性及功能。低功率射頻器材之使用不得影響飛航安全及干擾合法通信；經發現有干擾現象時，應立即停用，並改善至無干擾時方得繼續使用。前述合法通信，指依電信管理法規定作業之無線電通信。低功率射頻器材須忍受合法通信或工業、科學及醫療用電波輻射性電機設備之干擾。

應避免影響附近雷達系統之操作。

[本產品電磁波曝露量(MPE)標準值 $1\text{mW}/\text{cm}^2$ ，送測產品實測值為 $0.571\text{mW}/\text{cm}^2$ ，建議使用時至少距離人體 $23\text{cm}$ ]

[警語內容]

本器材須經專業工程人員安裝及設定，始得設置使用，且不得直接販售給一般消費。

## RoHS Statement

The Restriction of Hazardous Substances 2.0 (RoHS 2.0) in Electrical and Electronic Equipment Directive was passed into law by the European Union (EU). It affects manufacturers, sellers, distributors and recyclers of electrical and electronic equipment containing lead, cadmium, mercury, hexavalent chrome, polybrominated diphenylether (PBDE), polybrominated biphenyl (PBB), Bis (2-ethylhexyl) phthalate (DEHP), Butyl benzyl phthalate (BBP), Dibutyl phthalate (DBP) and Diisobutyl phthalate (DIBP). After June 4, 2015 the use of these materials are banned in new products sold in Europe.

WatchGuard declares that all products listed herein comply with European Union RoHS Directive (RoHS 2.0 2011/65/EU and 2015/863/EU) requirements taking the following Annex III exemptions: [stating the list of exemptions, 6(c), 7(a), 7(C)-1].

Access Points: AP130, AP330, AP332CR, AP430CR, AP432

Firebox: N5V, T25, T25-W, T45, T45-PoE, T45-W-PoE, T45-CW, T85-PoE, M290, M390, M590, M690

Substances Listed	Limit
Cadmium(Cd)	$\leq 0.01\%$ (100 ppm)
Hexa-valent Chromium (Cr6+)	$\leq 0.1\%$ (1000 ppm)
Lead (Pb)	$\leq 0.1\%$ (1000 ppm) *
Mercury (Hg)	$\leq 0.1\%$ (1000 ppm)
Polybrominated biphenyls (PBB)	$\leq 0.1\%$ (1000 ppm)
Polybrominated diphenylethers (PBDE or PBBE)	$\leq 0.1\%$ (1000 ppm)
Bis (2-ethylhexyl) phthalate (DEHP)	$\leq 0.1\%$ (1000 ppm)
Butyl benzyl phthalate (BBP)	$\leq 0.1\%$ (1000 ppm)
Dibutyl phthalate (DBP)	$\leq 0.1\%$ (1000 ppm)
Diisobutyl phthalate (DIBP)	$\leq 0.1\%$ (1000 ppm)

\* (contains Lead > 0.1% by weight because of exempted applications)

*7a lead in high melting temperature type solders (i.e. lead based alloys containing 85 % by weight or more lead)*

*7(c) I. Electrical and electronic components containing lead in a glass or ceramic other than dielectric ceramic in capacitors, e.g. piezo electronic devices, or in a glass or ceramic matrix compound.*

## WEEE Statement

WatchGuard asks that all our products to be recycled at the end of their current use to comply with local waste compliance requirements.

WatchGuard supports the EU Waste Electrical and Electronic Equipment (WEEE) Directive (2012/19/EU). That means that WEEE may not be disposed as unsorted municipal waste but is to be collected separately.

WatchGuard products are therefore labeled with this symbol:



The WEEE symbol on your WatchGuard equipment indicates that it should not be disposed of by the end user with unsorted municipal waste, but in a manner consistent with required EU Directives, and the local transposition of the Directive in the end user's jurisdiction. The symbol is placed per CENELEC standard EN50419.

WEEE may contain hazardous substances which may negatively affect the environment and human health when disposed of through normal channels. Batteries that are not enclosed in the waste equipment must be separated from it and disposed of separately before being handed in at a collection point. Old batteries, and in certain cases also the waste equipment, can likewise be returned free of charge to the point of sale. You are responsible for deleting any personal data on the waste equipment. WatchGuard is committed to reduce the negative environmental and human health effects of WEEE which will help prevent potential negative consequences for the environment and human health. If you are a consumer please use your local recycling option. This is usually your municipal refuse site.

## Limited Hardware Warranty

This Limited Hardware Warranty (the "Warranty") applies to the enclosed hardware product, not including any associated software, which is licensed pursuant to a separate end-user license agreement and warranty (the "Product"). BY USING THE PRODUCT, YOU (either an individual or a single entity) AGREE TO THE TERMS HEREOF.

If you do not agree to these terms, please return this package, along with proof of purchase, to the authorized dealer from which you purchased it for a full refund. WatchGuard Technologies, Inc. ("WatchGuard") and you agree as set forth below or on the reverse side of this card, as applicable.

- LIMITED WARRANTY.** WatchGuard warrants that upon delivery and for one (1) year thereafter (the "Warranty Period"): (a) the Product will be free from material defects in materials and workmanship, and (b) the Product, when properly installed and used for its intended purpose and in its intended operating environment, will perform substantially in accordance with WatchGuard applicable specifications.

This warranty does not apply to any Product that has been: (i) altered, repaired or modified by any party other than WatchGuard except for the replacement or inclusion of specified components authorized in, and performed in strict accordance with, documentation provided by WatchGuard; or (ii) damaged or destroyed by force majeure events, accidents, power spikes or similar events or by any intentional, reckless or negligent acts or omissions of any party. You may have additional warranties with respect to the Product from the manufacturers of Product components. However, you agree not to look to WatchGuard for, and hereby release WatchGuard from any liability for, performance of, enforcement of, or damages or other relief on account of, any such warranties or any breach thereof.

2. **REMEDIES.** If any Product does not comply with the WatchGuard warranties set forth in Section 1 above, WatchGuard will, following the receipt of the product you claim is defective and at its option, either (a) repair the Product, or (b) replace the Product with a like or similar product; provided, that you will be responsible for returning the Product and for all costs of shipping and handling. Repair or replacement of the Product shall not extend the Warranty Period. Any Product, component, part or other item replaced by WatchGuard becomes the property of WatchGuard. WatchGuard shall not be responsible for return of or damage to any software, firmware, information or data contained in, stored on, or integrated with any returned Products.
3. **DISCLAIMER AND RELEASE.** THE WARRANTIES, OBLIGATIONS AND LIABILITIES OF WATCHGUARD, AND YOUR REMEDIES, SET FORTH IN PARAGRAPHS 1 AND 2 ABOVE ARE EXCLUSIVE AND IN SUBSTITUTION FOR, AND YOU HEREBY WAIVE, DISCLAIM AND RELEASE ANY AND ALL OTHER WARRANTIES, OBLIGATIONS AND LIABILITIES OF WATCHGUARD AND ALL OTHER RIGHTS, CLAIMS AND REMEDIES YOU MAY HAVE AGAINST WATCHGUARD, EXPRESS OR IMPLIED, ARISING BY LAW OR OTHERWISE, WITH RESPECT TO ANY NONCONFORMANCE OR DEFECT IN THE PRODUCT (INCLUDING, BUT NOT LIMITED TO, ANY IMPLIED WARRANTY OF MERCHANTABILITY OR FITNESS FOR A PARTICULAR PURPOSE, ANY IMPLIED WARRANTY ARISING FROM COURSE OF PERFORMANCE, COURSE OF DEALING, OR USAGE OF TRADE, ANY WARRANTY OF NON-INFRINGEMENT, ANY WARRANTY OF UNINTERRUPTED OR ERROR-FREE OPERATION, ANY OBLIGATION, LIABILITY, RIGHT, CLAIM OR REMEDY IN TORT, WHETHER OR NOT ARISING FROM THE NEGLIGENCE (WHETHER ACTIVE, PASSIVE OR IMPUTED) OR FAULT OF WATCHGUARD OR FROM PRODUCT LIABILITY, STRICT LIABILITY OR OTHER THEORY, AND ANY OBLIGATION, LIABILITY, RIGHT, CLAIM OR REMEDY FOR LOSS OR DAMAGE TO, OR CAUSED BY OR CONTRIBUTED TO BY, THE PRODUCT).
4. **LIMITATION AND LIABILITY.** WATCHGUARD'S LIABILITY (WHETHER ARISING IN CONTRACT (INCLUDING WARRANTY), TORT (INCLUDING ACTIVE, PASSIVE OR IMPUTED NEGLIGENCE AND STRICT LIABILITY AND FAULT) OR OTHER THEORY) WITH REGARD TO ANY PRODUCT WILL IN NO EVENT EXCEED THE PURCHASE PRICE PAID BY YOU FOR SUCH PRODUCT. THIS SHALL BE TRUE EVEN IN THE EVENT OF THE FAILURE OF ANY AGREED REMEDY. IN NO EVENT WILL WATCHGUARD BE LIABLE TO YOU OR ANY THIRD PARTY (WHETHER ARISING IN CONTRACT (INCLUDING WARRANTY), TORT (INCLUDING ACTIVE, PASSIVE OR IMPUTED NEGLIGENCE AND STRICT LIABILITY AND FAULT) OR OTHER THEORY) FOR COST OF COVER OR FOR ANY INDIRECT, SPECIAL, INCIDENTAL, OR CONSEQUENTIAL DAMAGES (INCLUDING WITHOUT LIMITATION LOSS OF PROFITS, BUSINESS, OR DATA) ARISING OUT OF OR IN CONNECTION WITH THIS WARRANTY OR THE USE OF OR INABILITY TO USE THE PRODUCT, EVEN IF WATCHGUARD HAS BEEN ADVISED OF THE POSSIBILITY OF SUCH DAMAGES. THIS SHALL BE TRUE EVEN IN THE EVENT OF THE FAILURE OF ANY AGREED REMEDY.
5. **MISCELLANEOUS PROVISIONS.** This Warranty will be governed by the laws of the state of Washington, U.S.A., without reference to its choice of law rules. The provisions of the 1980 United Nations Convention on Contracts for the International Sales of Goods, as amended, shall not apply. You agree not to directly or indirectly transfer the Product or use of the product or associated documentation to any country to which such transfer would be prohibited by the U.S. Export laws and regulations. If any provision of this Warranty is found to be invalid or unenforceable, then the remainder shall have full force and effect and the invalid provision shall be modified or partially enforced to the maximum extent permitted by law to effectuate the purpose of this Warranty. This is the entire agreement between WatchGuard and you relating to the Product, and supersedes any prior purchase order, communications, advertising or representations concerning the Product AND BY USING THE PRODUCT YOU AGREE TO THESE TERMS. IF THE PRODUCT IS BEING USED BY AN ENTITY, THE INDIVIDUAL INDICATING AGREEMENT TO THESE TERMS BY USING THE PRODUCT REPRESENTS AND WARRANTS THAT (A) SUCH INDIVIDUAL IS DULY AUTHORIZED TO ACCEPT THE WARRANTY ON BEHALF OF THE ENTITY AND TO BIND THE ENTITY TO THE TERMS OF THIS WARRANTY; (B) THE ENTITY HAS THE FULL POWER, CORPORATE OR OTHERWISE, TO ENTER INTO THE WARRANTY AND PERFORM ITS OBLIGATIONS UNDER THE WARRANTY AND; (C) THE WARRANTY AND THE PERFORMANCE OF THE ENTITY'S OBLIGATIONS UNDER THE WARRANTY DO NOT VIOLATE ANY THIRD-PARTY AGREEMENT TO WHICH THE ENTITY IS A PARTY.

No change or modification of the Warranty will be valid unless it is in writing and is signed by WatchGuard.

*© 2023 WatchGuard Technologies, Inc. All rights reserved. WatchGuard and the WatchGuard logo are registered trademarks or trademarks of WatchGuard Technologies in the United States and other countries. Various other trademarks are held by their respective owners.*